

**Keltron 3084/3084-1  
 AA7 Security Transceiver**

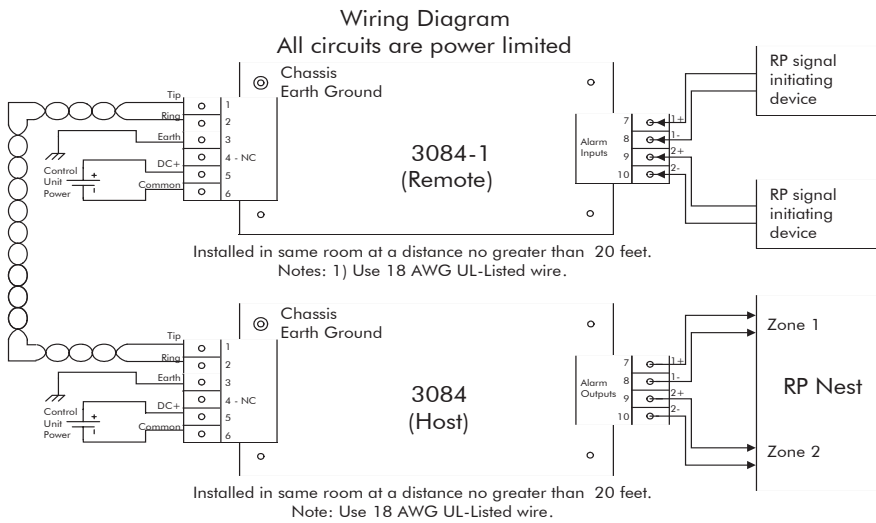

**Notes:**

1. Keltron AA7 Host is comprised of:
  - (a) 3084 printed circuit board and
  - (b) AABX enclosure
2. Keltron AA7 Remote is comprised of:
  - (a) 3084-1 printed circuit board and
  - (b) AABX enclosure
3. Conduit connections are required.  
 The UL Listed conduit boxes are:
 

Hoffman	A-SE10x8x4 (screw cover)
	A-SE10x8x3 (hinged cover)
Wiegmann	SC8104G (screw cover)
	A8104 (hinged cover)

**3084 AA7 Host Specifications**

Connection	Terminal lugs - accepts 16-26 AWG
Supply voltage	10-24 VDC regulated unsupervised
Supply current	70 mA maximum
RP (output)	Unsupervised
Number of outputs	2
Number of wires	4
Voltage	0 to 5 volts
Current	5V @ no load (decreases 0.5V/mA)
Response time	22 mA
Response time	4 seconds (maximum)
Modem (input/output)	Supervised
Impedance	600 ohms
Output power	-12 dBm
Input Sensitivity	-40dBm (0 dBm=1mW @ 600 ohms)
Isolation	Uses 1:1 transformer
Protection	Lightning
States	Alarm, Secure, Trouble
Supervision	Host supervises Remote
Capacity	Two outputs
Communication Medium	Two wire Telco (2000 series) or twisted pair direct line
Communication Method	Full Duplex Modem
Frequency range	1000Hz .. 2300Hz
Environmental	
Operating temperature	0 to 49°C
Storage temperature	-25 to 70°C
Relative humidity	non-condensing 20 to 85%
Dimensions (L x W x H)	
3084 (PC board)	5.0" x 3.5" x 1.0"
AABX (enclosure)	6.0" x 5.0" x 1.75"
Weight	
3084 (PC board)	0.27 lb
AABX (enclosure)	0.52 lb
Identificaton number	Factory programmed

**3084-1 AA7 Remote Specifications**

Connection	Terminal lugs - accepts 16-26 AWG
Supply voltage	10-24 VDC regulated unsupervised
Supply current	70 mA maximum
RP (input)	Class B supervised
Number of inputs	2
Number of wires	4
Voltage range	DC 3V minimum, 15V maximum
Current	2-10mA
Hold time	4 seconds (maximum)
Modem (input/output)	Supervised
Impedance	600 ohms
Output power	-12 dBm
Input Sensitivity	-40dBm (0 dBm=1mW @ 600 ohms)
Isolation	Uses 1:1 transformer
Protection	Lightning
States	Alarm, Secure, Trouble
Supervision	RP inputs are supervised
Capacity	Two inputs
Communication Medium	Two wire Telco (2000 series) or twisted pair direct line
Communication Method	Full Duplex Modem
Frequency range	1000Hz .. 2300Hz
Environmental	
Operating temperature	0 to 49°C
Storage temperature	-25 to 70°C
Relative humidity	non-condensing 20 to 85%
Dimensions (L x W x H)	
3084 (PC board)	5.0" x 3.5" x 1.0"
AABX (enclosure)	6.0" x 5.0" x 1.75"
Weight	
3084 (PC board)	0.27 lb
AABX (enclosure)	0.52 lb
Indentification number	Factory programmed

**General**

The Keltron AA7, or Double A Seven, consists of a matched host and remote pair (3084 / 3084-1). This equipment was designed to meet Underwriters Laboratory's (UL) criteria for transmitting alarm data over unsecured transmission lines. The criteria are described in UL publication 365 under 'Standard Line Security' equipment. When connecting these modules to any equipment it must have compatible ratings and be installed in accordance with the manufacturer's installation instructions.

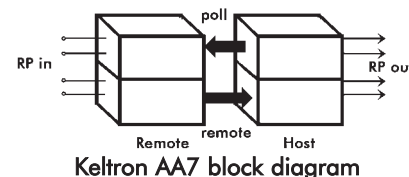

Keltron AA7 has the added convenience of (1) having two zones and (2) being able to communicate over voice grade lines.

**Installation**

Host and remote have identical connector pin assignments in pins 1 to 6. These are pins for communication, Earth ground, and power. Pins 1 and 2 connect to a 600 ohm telephone line. These lines are electrically isolated from the main circuit of the Keltron AA7. The pins are interchangeable. Pin 3 is the earth ground. Either this pin or the conductive mounting hole must be connected to an earth ground for the lightning protection circuit to work properly. Pins 5 and 6 are the positive and negative DC power inputs respectively.

Keltron AA7 handles two independent zones. Each zone may be used for a number of applications including monitoring of intrusion, fire, and non-critical industrial processes. Since the two zones are completely independent, if only a single zone is required, input and output terminals of the unused zone may be left open.

Pins 7, 8, 9, and 10 are the RP inputs in the remote. These inputs are opto-isolated and therefore operate on voltage differentials. The remote recognizes an input as Secure when RP+ is at least 3 volts higher than RP-. Alarm is when RP- is either at least 3 volts higher than RP+, or when the voltage is at an ambiguous level, namely, between +3 and -3 volts. The equipment driving the RP inputs must be capable of supplying at least 2mA. The voltage must not exceed 15 volts in either direction.

Pins 7, 8, 9, and 10 are the RP outputs at the host. Following the convention at the remote, RP1+ and RP1- pins are positive and negative respectively during a Secure (no alarm) state, and negative and positive respectively during an Alarm state. The host accomplishes the reversal of voltages by raising one line of the pair to 5 volts while holding down the other to 0 volts and doing the opposite for a different state. For this reason, it is mandatory that the RP inputs of the driven equipment be floating. The output voltage is 5 volts at no load and decreases as the load current increases. The rate is approximately half a volt per milliampere. One must make sure that this satisfies the input voltage and current requirements of the driven equipment. Keltron's 95DM726 meets these requirements. During a compromise or line trouble both RP1 and RP2 output voltages reverse.

**Supervision**

The remote supervises its inputs in that the absence of the proper forward voltage on an input causes an alarm signal to be transmitted independently for each input. The host supervises the remote, for this is the chief task of the AA equipment. When the remote loses power, the host goes into an alarm. The remote has a tamper switch. When the cover is removed from the remote, the host goes into alarm. The host is supervised by the equipment it connects to, so when the host loses power all output voltages disappear.

**Theory of Operation**

The host and remote pair utilize two-way communication over a dedicated telephone line. Frequency modulated AC signals are used to allow a variety of telephone lines ranging from voice grade lines such as fiber optic lines to DC lines such as copper lines between the two units.

Keltron AA7 is dedicated to the simple task of transmitting Reverse Polarity (RP) signals in a fashion to thwart defeat without detection. The remote unit, which is installed at a secure area of the protected premises, monitors two RP inputs. Upon receiving a query from the host, it transmits a data packet containing the states of the RP inputs. The host unit, which is installed at a central receiving station or Police department, converts the received data packet back into RP. Owing to the sophisticated two-way communication scheme, Keltron AA7 has immunity against noise-induced false alarms as well as deliberate tampering.

Keltron 3084-1 Remote Unit Connector Definition				Keltron 3084 Host Unit Connector Definition			
Pin #	Name	Type	Description	Pin#	Name	Type	Description
1	Tip	Bidirectional	Connects to one side of the telephone line	1	Tip	Bidirectional	Connects to one side of the telephone line
2	Ring	Bidirectional	Connects to the other side of the telephone line	2	Ring	Bidirectional	Connects to the other side of the telephone line
3	Earth	Input	Earth ground	3	Earth	Input	Earth ground
4			No connection	4			No connection
5	DC+	Input	Positive 10 - 24 volts DC power input	5	DC+	Input	Positive 10 - 24 volts DC power input
6	Common	Input	Negative DC power input	6	Common	Input	Negative DC power input
7	RP1+	Input	1st zone RP input (positive during Secure)	7	RP1+	Output	1st zone RP output (pos. during Secure)
8	RP1-	Input	1st zone RP input (negative during Secure)	8	RP1-	Output	1st zone RP output (neg. during Secure)
9	RP2+	Input	2nd zone RP input (positive during Secure)	9	RP2+	Output	2nd zone RP output (pos. during Secure)
10	RP2-	Input	2nd zone RP input (negative during Secure)	10	RP2-	Output	2nd zone RP output (neg. during Secure)

