

**Installation and Operation Manual  
Keltron 90 Series Miniprinter**



# Table of Contents

<b>1 Keltron 90 Series</b> .....	<b>1</b>	and protocol .....	10
1.1 Introduction .....	1	4.3.2 Current loop specification .....	10
1.2 Model Number .....	1	4.3.3 Interface timing diagrams .....	10
1.3 Specifications .....	1	<b>5 Maintenance and supplies</b> .....	<b>11</b>
1.3.1 General specifications .....	1	5.1 Replacing printer paper and ribbon ...	11
1.3.2 Electrical specification .....	2	5.3 Warranty .....	12
1.3.3 Environmental specifications .....	2	<b>Appendix A Switch pack settings</b> .....	<b>13</b>
1.3.4 Mechanical specifications .....	2	<b>Appendix B List of U.L. models</b> .....	<b>14</b>
<b>2 Description</b> .....	<b>3</b>	<b>Appendix C Model VS4095/4</b> .....	<b>15</b>
2.1 Introduction .....	3	C.1 8 Bit parallel interface .....	15
2.2 Printer controller .....	3	C.1.1 Parallel interface operation .....	15
2.3 Printer mechanism .....	3	C.1.2 Parallel interface specifications .....	15
2.4 Front panel controls .....	3	C.1.3 Interface timing diagrams .....	16
2.5 Side panel .....	4	<b>Addendum VS90V2.6</b> .....	<b>17</b>
2.5.1 Dipswitch setting .....	5		
2.5.2 Input/output connectors .....	5		
2.5.3 Power input .....	5		
<b>3 Operation</b> .....	<b>6</b>		
3.1 Selecting an interface .....	6		
3.2 Printer operating modes .....	6		
3.2.1 Line/buffer mode .....	6		
3.2.2 Normal/inverted print modes .....	6		
3.2.3 CR-LF=CR/Print all modes: .....	6		
3.3 Character set .....	6		
3.4 Character size .....	7		
3.5 System error prints and indications .....	8		
<b>4 Interface options</b> .....	<b>9</b>		
4.1 Serial RS232C .....	9		
4.1.1 Communication speed and protocol	9		
4.1.2 RS232 Technical specification .....	9		
4.2 Serial RS422 .....	9		
4.2.1 RS422 communication speed and protocol	10		
4.2.2 RS422 technical specifications .....	10		
4.3 Serial 20ma current loop .....	10		
4.3.1 Current loop communication speed			

## List of Figures

Figure 2.1 Standard 90 Series front panel .....	4
Figure 2.2 Side panel .....	5
Figure 4.1 Serial interface timing diagram .....	10
Figure 5.1 VS90 paper path .....	11
Figure A Switch pack #1 & #2 .....	13
Figure C.1 Parallel interface timing diagram .....	16

## List of Tables

Table 1.1 Model number convention .....	1
Table 2.1 Typical powerup printout .....	3
Table 2.2 Summary - voltage, current and fuse requirements .....	5
Table 3.1 Printer character set .....	6
Table 4.1 RS232 pin outs .....	9
Table 4.2 RS422 pin outs .....	9
Table 4.3 Current loop pin outs .....	10
Table 5.1 Supplies for VS90 .....	12
Table C.1 Parallel interface pin outs .....	15

# 1 Keltron 90 Series

## 1.1. Introduction

Congratulations on selecting the Keltron 90 Series printer. This series features a compact, reliable, two color dot matrix printer capable of printing at 2.3 lines/second on 3" wide paper. Each printed line may contain a maximum of 42 columns. Packaged in a rugged metal enclosure, it is available as a panel mount unit.

This series is available with three built-in communication interfaces to ease connection to a host computer. The standard 8192 character print buffer frees the host computer during the printing process. This series supports all standard communication handshakes and features easily accessible dipswitches to select communication and printing features.

## 1.2. Model number

The model number of your unit is printed on the serial number tag and the 90 Series model number convention is illustrated in Table 1.1.

Example:	V	S	42	9	5/	5
	V	S	xx	9	x/	x
(1) Printer case						
(2) # of print columns						
(3) Series						
(4) Power option						
(5) Interface option						

**Table 1.1 Model number convention**

- (1) Printer case: V = 4" deep vertical mount model
- (2) Number of print columns: A maximum of 42
- (3) Series: 9 = 95M3029-3 printer controller
- (4) Power option: 5 = +24VDC
- (5) Interface option: 5 = Serial RS232 and serial current loop with graphics  
7 = Serial RS422 and serial current loop with graphics

## 1.3. Specifications

### 1.3.1. General specifications

- Character set: 96 character upper and lower case ASCII
- Print buffer: 8192 characters
- Print method: Dot matrix impact
- Print fonts: Normal font -Normal character: 5 X 7 dot matrix  
-Extended character: 5 X 14 dot matrix  
Compressed font -Normal character: 7 X 7 dot matrix  
-Extended character: 7 X 14 dot matrix
- Print columns: A maximum of 42
- Print speed: -2.3 lines/second (at 26.4 VDC) to 1.9 lines/second (at 21.6 VDC) without red/black selection  
-2.2 lines/second (at 26.4 VDC) to 1.8 lines/second (at 21.6 VDC) with red/black selection
- Reliability: 1,500,000 lines
- Character size: # Columns 42  
Wide (mm) 1.3  
Height (mm) 2.9  
Dots/line 210
- Paper feed: Unidirectional (forward) pressure roller
- Paper: Thickness (in): 0.0027  
Diameter (in): 3.00  
Width (in): 3.00
- Inking/color: Snap-in ribbon cassette red/black

### 1.3.2. Electrical specification

Interface: Supports following types of interfaces  
Serial RS232C  
Serial RS422  
Serial 20ma current loop

Protocol: In serial mode, RTS/CTS & XON/XOFF are supported.

Communications: In serial mode, following baud rates - supported: 110, 150, 300, 600, 1200, 2400, 4800, 9600

Setting: All print and communication features are dipswitch selectable.

Input power: 24.0 +10% -15% VDC filtered  
Fuse 2.0A slow blow  
Idle: 60mA, average printing: watts: 24

Power connector: Two-position screw/terminal strip

### 1.3.3. Environmental specifications

Temperature range: Operating: 0EC to 49EC  
Storage: -25EC to 70EC

Relative humidity: Non-condensing 20% TO 85%

### 1.3.4. Mechanical specifications

Case material: Metal

## 2. Description

### 2.1. Introduction

The basic 90 Series printer is comprised of a microcomputer-based printer controller, a printer mechanism module, a power supply module, and a metal enclosure.

### 2.2. Printer controller

The VS90 Series printers use the Keltron part number 95M3029-3 universal printer control card. This card holds the printer drivers, communication interfaces, 8K print buffer and dipswitches. A powerful INTEL micro controller on the 95M3029-3 board manages all tasks and features supported by the VS90 Series printers.

Upon initial power up, the VS90 Series goes through extensive self-test, verifies the amount of print buffer installed, and checks for presence of the various options installed. Also, the dipswitches are read to set the operating features selected by the operator.

If the front panel TEST switch is pushed during power up, the printer prints on three lines, the amount of print buffer found, the printer model number, and the type of interface selected, the interface setting selected, and a list of options installed.

A typical power up print may look like this:

8K buffer.....	VS4295/5
Interface.....	Serial
Mode.....	9600, 8, O, 2, #

**Table 2.1 Typical power up printout**

In the idle mode, the printer continuously checks the front panel controls, and the paper out detector, and services the print buffer, and the internal processor watchdog monitor.

The controller receives the data sent to the VS90 Series on an interrupt basis. The controller validates the data before saving it in the print queue.

### 2.3. Printer mechanism

The Keltron VS90 Series printers are designed using highly reliable alphanumeric impact printer mechanisms. They print 5x7 or 7x7 dot matrix characters using a continuous, pre-inked two-color ribbon cassette. The printer mechanism requires +24 VDC for operation. A special protection circuit included on the control card guards the printer mechanism against possible malfunction.

### 2.4. Front panel controls

All the operator controls for the VS90 Series printers are located on the front panel assembly of the unit.

A dual function switch mounted on the front panel is used for manual **TEST** print and paper **FEED** during normal operation.

The two LEDs mounted on the front panel are used for various indications.

The data terminal ready **DTR** LED indicates that the printer is ready to receive data from a host computer.

The end of paper **EOP** LED indicates that the printer is out of paper.

**FWD/RVS** switch controls the operation of the paper take up.

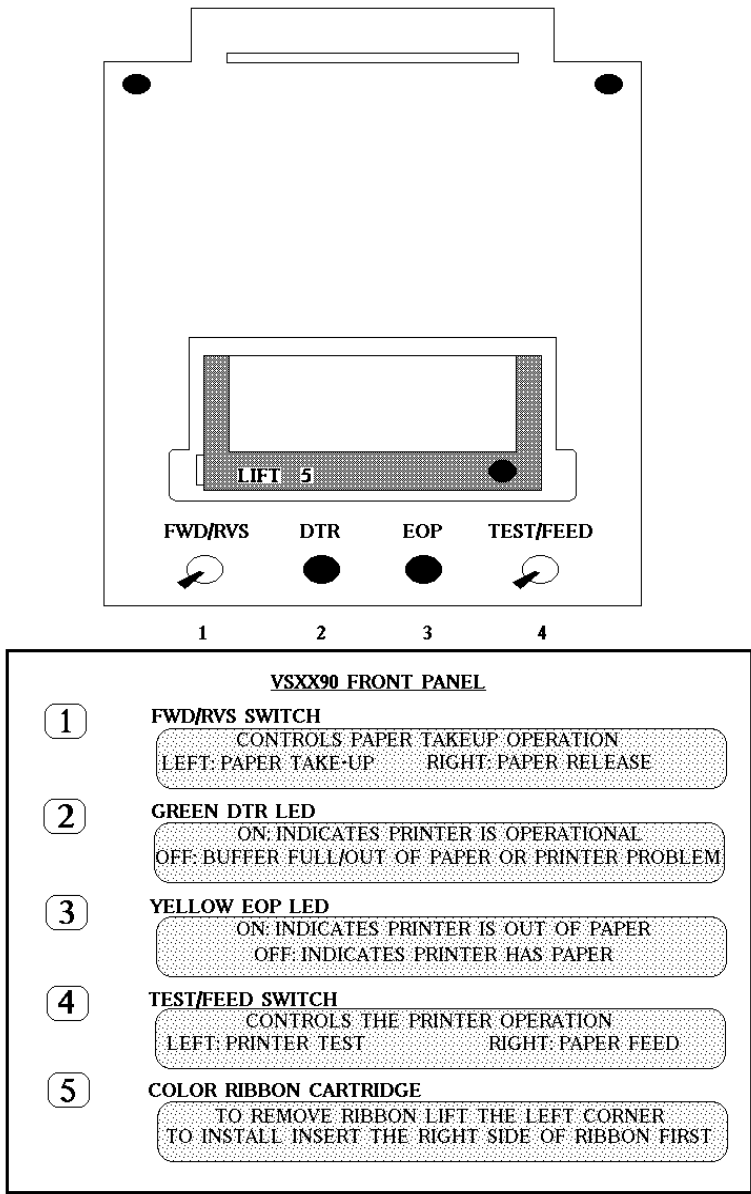

Figure 2.1 Standard 90 Series front panel

2.5. Side panel

The dipswitches to set the printer functions, the data input/output connectors, power fuse, and power input connector are located on the right side panel of the 90 Series printers. A standard side panel is shown in Figure 2.2.

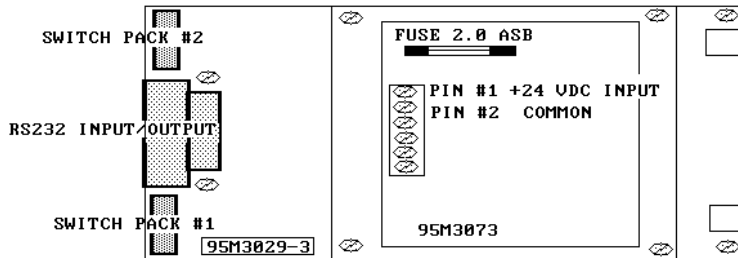

Figure 2.2 Side panel

### 2.5.1. Dipswitch setting

Two 8-position dipswitches are provided to set the print functions and communication protocols.

Switch pack #1 is used to set the serial port protocols, while switch pack #2 is used to set the printer features and functions.

Appendix A lists the functions of switch pack #1 and switch pack #2.

### 2.5.2. Input/output connectors

All the serial input/output signals of the 90 Series printers are terminated on the DB25S style connector. Pin assignments for each type of interface are listed in Section 4.

### 2.5.3. Power input

90 Series printers require +24 VDC for operation. The Table 2.2 below summarizes voltage, current and fuse requirements.

Model#	Voltage	+/-	Fuse
VS4295/X	24.0VDC	+10/-15%	2.0ASB
VS4095/X	24.0VDC	+10/-15%	2.0ASB

Table 2.2 Summary - voltage, current and fuse requirements

A terminal strip is used to bring power to vertical mount DC units.

\*\*\*\*\*

**Caution!!!!!!!!!! Do Not Reverse Polarity !!!!!!!!!!!**

\*\*\*\*\*

### 3. Operation

#### 3.1. Selecting an interface

Switches #1 and #2 on switch pack #2 are used to select one of the three interfaces built into your unit. Settings of these switches are checked only on power up. The printer will print the type of interface selected on power up. Refer to Appendix A for proper setting.

If the serial interface or the current loop is selected, the serial communication protocol switches must be set. Refer to Appendix A for proper setting.

#### 3.2. Printer operating modes

##### 3.2.1. Line/buffer mode

The 90 Series printers can operate in two modes: Buffer or line mode. In buffer mode, the unit does not print until either the printer buffer has less than 256 locations remaining for additional characters, or an EOT (^D) character is received. In line mode, the unit begins printing as soon as 42 characters are stored in the print buffer. Or a CR, LF, VT, FF character is received. Switch #8 on switch pack #2 is used to select these operating modes as indicated in Appendix A.

##### 3.2.2. Normal/inverted print modes

The 90 Series printers can print in two modes: Normal or inverted. In normal mode, the data is printed in lister mode with the last line printed appearing at the top of the page. In inverted mode, the data is printed in text mode with the last line printed appearing at the bottom of the page. Switch #7 on switch pack #2 is used to select these operating modes as indicated in Appendix A.

##### 3.2.3. CR-LF=CR/Print all modes:

The 90 Series printers can be set to operate in two modes - CR/LF or print all modes. In the print all mode, all CR and LF characters received are processed. In the CR/LF mode, the following actions are taken on received data:

1. IF CR-LF is received, it is converted to LF.
2. If CR-LF is received, after 42 characters, i.e., a full line, CR and LF will be ignored.

Switch #5 on Switch Pack #2 is used to select these operating modes as indicated in Appendix A.

#### 3.3. Character set

The character set of 90 Series printers include 96 upper and lower case ASCII characters as listed in TABLE 3.1 below:

DATA BITS 3210	DATA BITS 654							
	000	001	010	011	100	101	110	111
0000	NUL		Space	0	@	p	.	p
0001			!	1	A	Q	a	q
0010			"	2	B	R	b	r
0011			#	3	C	S	c	s
0100	EOT		\$	4	D	T	d	t
0101			%	5	E	U	e	u
0110		SO	&	6	F	V	f	v
0111		SI	'	7	G	W	g	w
1000	BS		(	8	H	X	h	x
1001	HT		)	9	I	Y	i	y
1010	LF		*	:	J	Z	j	z
1011			.	;	K	[	k	{
1100	FF		\	<	L	\	l	:
1101	CR		-	=	M	]	m	}
1110	*SO*		.	>	N	!	n	~
1111	*SI		/	?	O	.	o	DEL

Table 3.1 Printer character set

### Character set (continued)

In addition to this character set, the following control characters are recognized:

Character	Control	Hex	Action
EOT	( ^D)	04	End of text If printer is in buffer mode, it prints content of buffer. If printer is in line mode, line feed only.
BS	( ^H)	08	Back space Remove previous character in buffer.
HT	( ^I)	09	Horizontal tab Tab to 5, 9, 13, 17, 21, 25, 29, 33, 37, or beginning of next line.
LF	( ^J)	0A	Line feed Advance to beginning of next line.
VT	( ^K)	0B	Vertical tab Advance 5 lines.
FF	( ^L)	0C	Form feed Advance 11 lines.
CR	( ^M)	0D	Carriage return Advance to beginning of next line.
SO	( ^N)	0E	Shift out All succeeding characters are printed in extended height.
SI	( ^O)	0F	Shift in All succeeding characters are printer in normal height.
XON	( ^Q)	11	Transmitter on Transmitted if the printer is on line to accept data. If received, the host computer is ready to accept data.
AUX ON	( ^R)	12	Print head on Transmitted on power up if the print head is operating. Transmitted after loading paper in the printer. If received, red print is selected.
XOFF	( ^S)	13	Transmitter off Transmitted if print buffer is full. Transmitted if out of paper. If received, host computer is off line.
AUX OFF	( ^T)	14	Print head off Transmitted on power up if the print head is not operating. Transmitted if out of paper. If received, black print is selected.
ESC	( ^[)	1B	Escape Used during dot addressable graphics mode.

### 3.4. Character size

The characters printed by the 90 Series printers can have two sizes: Normal and extended. The normal size characters are formed using a 5x7 dot matrix, or 7x7 dot matrix. The extended size characters are formed using a 5x14 dot matrix, or 7x14 dot matrix.

Extended print can be selected by three methods:

1. - Putting switch pack #2 - switch #6 on, will force extended print.
2. - Setting bit 8 of data sent to the printer will force that character to be printed in extended format.
3. - Through the serial port by sending the SO control character to select extended print or SI to select normal size.

Normal and extended characters can be printed on the same print line.

### 3.5. System error prints and indications

If the 90 Series printer encounters system errors during normal operation, it will alert the operator by printing an Error Message, or turning off the front panel LED.

Various system errors are listed below:

<b>Error</b>	<b>Action</b>
1 – Out of paper	EOP LED located on the front is turned on. AUX OFF is transmitted on serial ports.
2 – Printer head jam	Gives indications identical to "out of paper"
3 – Data receive error	The message is printed if the host computer sends data ignoring hand shake protocols. (Received data will be lost.)

## 4. Interface options

### 4.1. Serial RS232C

The RS232C Interface signals for the 90 Series printers are terminated on a DB25S type connector located on the 95M3029-3 controller. Five connections are needed from the Serial Interface to the host computer for proper operation of this option. Table 4.1 lists the serial interface signals and pin outs on the DB25S connector.

VS90	Description	
DB25S Pin#		
1	Protective ground	
2	RS232 out	TXD
3	RS232 in	RXD
4	Request to send output	RTS
5	Clear to send input	CTS
7	Common	COM

Table 4.1 RS232 pin outs

#### 4.1.1. Communication speed and protocol

The proper baud rate and protocol settings are required to communicate with a host computer. Dipswitches 1, 2, and 3 on switch pack #1 control the baud rate, while switches 4, 5, and 7 control the protocol as shown in Appendix A. The standard factory setting is 9600 baud, 8 data bits, odd parity bit, and one stop bit.

The VS90 Series printers support two communication protocols.

#### Serial busy protocol:

In this mode, Pins 4 (RTS) and 5 (CTS) are used to control data flow to and from the printer.

Pin #4 is used to control the data flow to the printer, which raises RTS when it is ready to accept data and lowers RTS under any of the following conditions:

- 1 – print buffer has less than 256 locations
- 2 – paper out
- 3 – test or feed is selected

### 4.2. Serial RS422

The RS422 Interface signals for the VS90 Series printers are terminated on a DB25S type connector located on the 95M3029-3 controller.

Nine (9) connections are needed from the serial Interface to the host computer for proper operation of this option. Table 4.2 lists the serial Interface signals and pin outs on the DB25S connector.

#### XON/XOFF protocol:

The unit transmits XON when it is ready to accept data, and XOFF for conditions 1 through 3 listed above.

Pin #5 (CTS) is monitored during data transmission from the printer. The unit transmits only if CTS is high under the serial busy protocol. In XON/XOFF protocol, the data flow out of the serial port is halted on XOFF and resumed on XON.

#### 4.1.2. RS232 technical specification

Data transfer rate: 110-9600 baud  
 Word length: 1 start, 7 or 8 data bits, 1 or 2 stops  
 Signal levels: Mark or logical 1 = -3 to -15VDC  
 Space or logical 0 = +3 to 15VDC  
 Handshaking: RTS/CTS, XON/XOFF, ACK mode (optional)

VS90	Description	
DB25S Pin#		
1	Protective ground	
2	RS422 out +	TXD +
9	RS422 out -	TXD -
3	RS422 in +	RXD +
10	RS422 in -	RXD -
4	Request to send output +	
11	Request to send output -	
5	Clear to send input +	CTS +
12	Clear to send input -	CTS -
7	Common	COM

Table 4.2 RS422 Pin outs

#### 4.2.1. RS422 communication speed and protocol

Refer to Section 4.1.1 for communication speeds and protocols.

#### 4.2.2. RS422 technical specifications

Data transfer rate: 110-9600 baud  
 Word length: 1 start, 7 or 8 data bits, 1 or 2 stops  
 Signal levels: Mark or logical 1=(SIG+) - (SIG-) >+200 millivolts  
 Space or logical 0=(SIG+) - (SIG-) >-200 millivolts  
 Handshaking: RTS/CTS, XON/XOFF, ACK mode (optional)

#### 4.3. Serial 20ma current loop

The serial 20ma current loop interface signals for the VS90 series printers are terminated on a DB25S type connector located on the 95M3029-3 controller. Four connections are needed from the serial Interface to the host computer for proper operation of this option. Table 4.3 lists the Serial Interface signals and pin outs on the DB25S connector.

VS90 DB25S Pin#	Description	
1	Protective ground	
14	20ma out +	TXD +
13	20ma out -	TXD -
16	20ma in +	RXD +

**Table 4.3 Current loop pin outs**

#### 4.3.1. Current loop communication speed and protocol

Only the XON/XOFF protocol is supported by the current loop Interface. Refer to Section 4.1.1 for communication speeds and protocols.

#### 4.3.2. Current loop specification

Data transfer rate 110-9600 baud  
 Word length: 1 start, 7 or 8 data bits, 1 or 2 stop bits  
 Signal levels: Mark or logical 1= current on  
 Space or logical 0= current off  
 Maximum voltage = +/- 5VDC  
 Maximum current = 40ma  
 Handshaking: XON/XOFF, ACK mode optional

#### 4.3.3. Interface timing diagrams

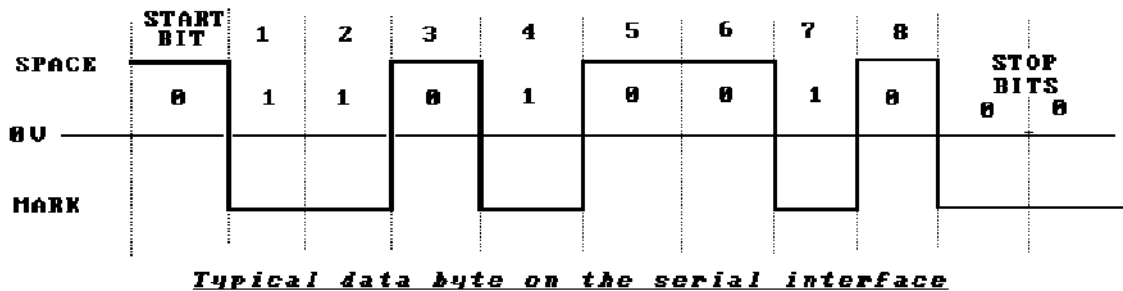

**Figure 4.1 Serial interface timing diagram**

## 5. Maintenance and supplies

### 5.1. Replacing printer paper and ribbon

The print paper tray of the VS90 Series printer is located behind the front panel.

- A. Advance the paper using the feed switch until the paper is removed from the print head.
- B. Open the printer faceplate.
- C. Remove the drive belt from the motor pulley and the take-up spool pulley.
- D. Move the take-up spool clip and slide out the take-up spool.
- E. Remove the paper from the take-up spool by sliding it to the end opposite that of the take-up spool pulley.
- F. Put the new roll of paper on the shaft and mount in the holder. Put the faceplate on temporarily to make sure that the paper has enough room to move freely.
- G. Feed the paper into the print head using the feed switch.
- H. Feed the paper through the faceplate slot.
- I. Attach the paper to the take-up spool by folding the paper back slightly (in a triangular fashion) and feed into the take-up spool slot. Roll up some of the paper on the spool for proper tightness. (Be sure that the paper is on bottom of the spool or it will unwind when the motor is operating.)
- J. Move the take-up spool clip and slide the take-up spool back into its seating position. Make sure that the take-up spool clip engages over the end of the spool.
- K. Attach the drive belt to the motor pulley and the take-up spool pulley.
- L. Use the feed switch to take-up any slack in the paper.
- M. Use the test switch to perform a manual reset. This tells the printer to resume printing the contents of its print buffer.

**\*\*\*NOTE: \*\*\***

When replacing the paper, never remove the power from the printer. If you do, you will empty the contents of your print buffer.

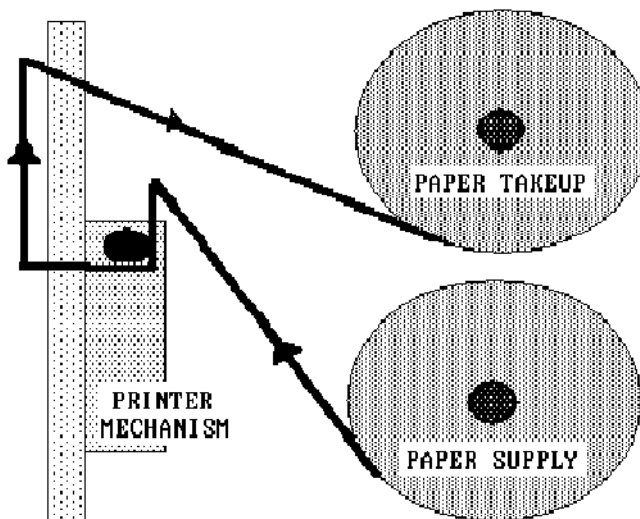

Figure 5.1 VS90 paper path

### 5.3. Supplies

Description	Keltron part number
Roll paper	10S212
Ribbon cartridge	10S220
Data input connectors:	
Serial connectors	21U001 & 21U003
Parallel connector	21C336

**Table 5.1 Supplies for VS90**

### 5.3. Warranty

The Keltron Corporation warrants all its products against defects in workmanship, materials, and construction under normal use and service, for a period of one year.

#### Contact Information

**KELTRON HEADQUARTERS**  
Keltron Corporation  
225 Crescent Street  
Waltham, Massachusetts 02453  
Telephone: 781-894-8710  
Toll Free: 800-966-6123  
FAX: 781-899-9652  
Email: info@keltroncorp.com

#### GENERAL

Telephone: 781-894-8710  
E-mail: info@keltroncorp.com

#### SALES

Telephone: 781-894-8710 X26  
E-mail: sales@keltroncorp.com

#### SUPPORT & SERVICES

Telephone: 781-894-8710 X18  
E-mail: support@keltroncorp.com

Appendix A Switch pack settings  
Serial interface setting

Switch pack #1

Switch #	A) Baud rate settings			
1,2,3	Baud rate	SW1	SW2	SW3
	110	ON	ON	ON
	150	OFF	ON	ON
	300	ON	OFF	ON
	600	OFF	OFF	ON
	1200	ON	ON	OFF
	2400	OFF	ON	OFF
	4800	ON	OFF	OFF
	9600	OFF	OFF	OFF
	B) Word length			
4	Number of data bits	SW4		
	8	OFF		
	7	ON		
	C) Parity settings			
5,6	Parity	SW5	SW6	
	Even	OFF	ON	
	Off	OFF	OFF	
	Disabled	ON	OFF	
7	D) Number of stop bits		SW7	
	1 stop		ON	
	2 stops		OFF	
8	E) Input error select			SW8
	Print characters received UART error			ON
	Print # on UART received error			OFF

Printer functions settings

Switch pack #2

Switch #		
1	A) Type of interface	
	ON	Not used
	OFF	RS232/RS422 serial interface is selected
2	B) Current loop select	
	ON	Current loop is selected
	OFF	Current loop is off
3	C) Set clock/calendar	
	Not used	
4	D) This must always be off	
5	E) CR-LF/print all mode	
	ON	Print all is selected
	OFF	CR-LF=LF is selected
6	F) Extended/normal print	
	ON	Force extended print
	OFF	Normal print is selected
7	G) Text/list print	
	ON	Print inverted/text
	OFF	Print normal/list
8	H) Line/buffer mode	
	ON	Buffer mode is selected
	OFF	Line mode is selected



Figure A.1 Switch pack #1 & #2

## Appendix B List of U.L. models

+24VDC, 42 column maximum:

VS4095/5 RS232 Interface, 40 a maximum columns.

VS4095/7 RS422 Interface, 40 a maximum columns.

VS4295/5 RS232 Interface, 42 a maximum columns.

VS4295/7 RS422 Interface, 42 a maximum columns.

## Appendix C Model VS4095/4

### C.1 8-bit parallel interface

The Parallel Interface signals for the 90 Series Miniprinters are terminated on a 36 pin Amphenol connector located on the rear of the printer.

Table C.1 lists the Parallel Interface signals and the connector pin outs. A (/) before a signal name indicates the signal is ACTIVE LOW; otherwise the signal is ACTIVE HIGH.

Pin#	Signal name	Direction	Function
1	/Strobe	IN	Data ready to be read
2	Data 1	IN	Data bit received 1
3	Data 2	IN	Data bit received 2
4	Data 3	IN	Data bit received 3
5	Data 4	IN	Data bit received 4
6	Data 5	IN	Data bit received 5
7	Data 6	IN	Data bit received 6
8	Data 7	IN	Data bit received 7
9	Data 8	IN	Data bit received 8
10	/Ack	OUT	Data received acknowledge
11	Busy	OUT	Printer busy
12	PE	OUT	Paper out error
13	Selected	OUT	Printer is on line
14-15			No connection
16	Common		Signal common
17	Ground		Chassis ground
18			No connection
19-30	Common		Signal common
31	/Prime	IN	External printer reset
32	/Fault	OUT	Printer fault

Table C.1 Parallel interface pin outs

#### C.1.1 Parallel interface operation

Pin #1, of the parallel interface connector, carries the /STROBE signal from the host computer to the printer. This signal is held at TTL HIGH level normally, and lowered by the computer when the data is ready for the printer. A flip-flop located on the printer control card latches the /STROBE signal, and interrupts the processor to read, validate, and save the data received.

Also, the busy signal (Pin#11) is set to indicate that the printer is busy reading data received.

Upon saving the data received, the printer lowers /ACK (Pin #10) to acknowledge that data has been received, and lowers the busy signal.

Refer to APPENDIX A for proper printer functions settings.

#### C.1.2 Parallel interface specifications

Data transfer rate: 6000 characters/second  
Synchronization: via strobe line  
Handshaking: ack and busy signals  
Signal levels: compatible with TTL level

C.1.3 Interface timing diagrams

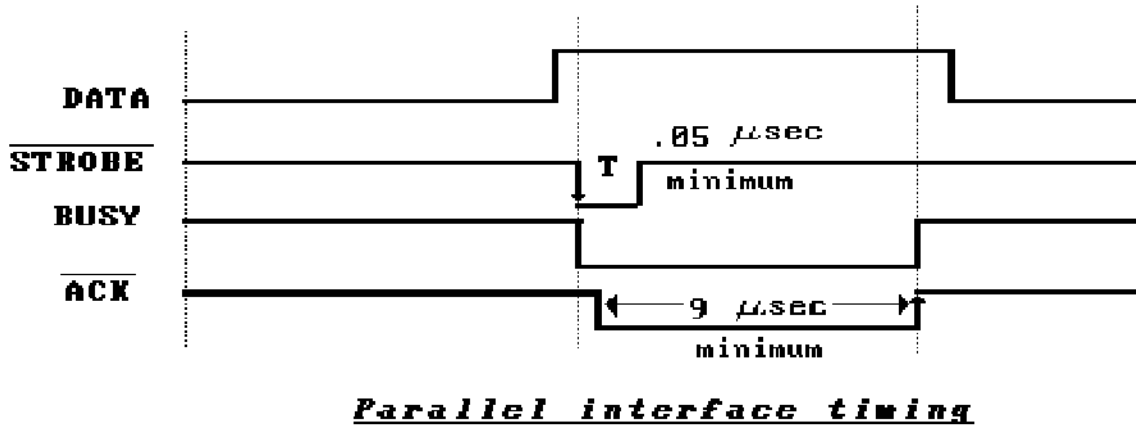

Figure C.1 Parallel interface timing diagram

## Addendum VS90V2.6

### VS90 Printer battery backed clock/calendar option

Battery backed CLOCK/CALENDAR option can be installed in the VS90 Series printers. The option, PART# 31D1243, is installed in socket #10 of the printer control card (PART# 95M3029).

On initial power up, the printer senses the presence of the BATTERY BACKED-UP CLOCK/CALENDAR, and uses its setting to set the printer clock.

The presence of the CLOCK/CALENDAR option can be verified, by holding the <TEST> switch during the initial power up of the printer. The printer prints the "CLOCK INSTALLED" message if the CLOCK/CALENDAR option is found.

### VS90 Printer battery backed clock/calendar operation

The TIME CLOCK provides military time. Hours, minutes and seconds can be printed.

The CALENDAR automatically compensates for leap years. Months, days and years can be printed.

The CLOCK/CALENDAR information can be printed using the front panel <TEST> switch.

The CLOCK/CALENDAR is printed on a single line, in the following format:

**HOURS: MINUTES: SECONDS MONTHS/DAYS/YEARS**

**12 : 59 : 59 12 / 31 / 93**

### SETTING THE CLOCK/CALENDAR FEATURE

To start the CLOCK/CALENDAR setting procedure - put Dipswitch #3 on SWITCH PACK #2 ON.

This places the printer in the CLOCK SET MODE, and the printer prints the current clock and calendar setting.

**SET HOURS 12:30:00 04/24/93**

Once in the CLOCK SET MODE, the time and date can be set using the <FWD> and <RVS> switches located on the front panel of the unit.

The current CLOCK/CALENDAR setting can be printed by using the front panel <TEST> switch.

Setting of the CLOCK/CALENDAR is done from left to right in the following order:

### HOURS/MINUTES/MONTHS/DAYS/YEARS

STEP 1 / 2 / 3 / 4 / 5

There are a total of five fields to set HOURS, MINUTES, MONTHS, DAYS, and YEARS. Initially, the HOURS field is selected for setting.

The <FWD> switch is used to step from one field to next, while the <RVS> switch is used to advance the setting of the field selected.

#### SET HOURS

1. TO ADVANCE THE SETTING OF THE HOURS FIELD, press the <RVS> SWITCH. The HOURS setting will advance by one for each pressing of the <RVS> SWITCH.

Use the <TEST> SWITCH to check the HOURS setting.

#### SET MINUTES

2. TO ADVANCE TO THE MINUTES FIELD, press the <FWD> SWITCH once. The printer prints the following message to indicate that MINUTES field has been selected.

**SET MINUTES 12:30:00 11/04/93**

Advance the minutes using the <RVS> SWITCH. Use the <TEST> SWITCH to check the MINUTES setting.

#### SET MONTHS

3. TO ADVANCE TO THE MONTHS FIELD press the <FWD> SWITCH once. The printer prints the following message to indicate that MONTHS field has been selected.

**SET MONTHS 12:30:00 11/04/93**

Advance the MONTHS using the <RVS> SWITCH. Use the <TEST> SWITCH to check the MONTHS setting.

## SET DAYS

4. TO ADVANCE TO THE DAYS FIELD press the <FWD> SWITCH once. The printer prints the following message to indicate that DAYS field has been selected.

SET DAYS 12:30:00 11/04/93

Advance the DAYS using the <RVS> SWITCH. Use the <TEST> SWITCH to check the DAYS setting.

## SET YEARS

5. TO ADVANCE TO THE YEARS FIELD press the <FWD> SWITCH once. The printer prints the following message to indicate that YEARS field has been selected.

SET YEARS 12:30:00 11/04/93

Advance the YEARS using the <RVS> SWITCH. Use the <TEST> SWITCH to check the YEARS setting.

NOTE: The Years are looped from 93 through 30. Thus the next Year after 30 will be 93.

Pressing the <FWD> switch after selecting the years setting loops the clock set procedure back to SET HOURS.

## **EXIT CLOCK SET MODE**

To EXIT the CLOCK/CALENDAR set mode - put the Dipswitch #3 on SWITCH PACK #2 OFF. The printer prints the current time and date before exiting the clock set mode.

## **POWER LOSS TIME AND DATE STAMP FEATURE**

The VS90 printer-operating program continuously monitors the power input and updates the non-volatile time and date registers.

The last registered time and date stamp is automatically printed after restoring power to the printer.

The normal power up print looks as follows.

CURRENT TIME AND DATE

22:30:44 11/24/93

LAST TIME AND DATE

12:30:15 10/24/93